

9146-R Smart Connector

Connectors for the PSI 9146-R

- Enables 'plug-and-play' type operation of the 9146-R with a variety of input types.
- All transducer's information is contained within the plug so they become a 'TEDS' type device.

Thermocouple

- $\pm 0.25^{\circ}\text{C}$ accuracy typical, $\pm 0.7^{\circ}\text{C}$ accuracy max (N type T/C)
- Remote cold junction.
- Remote connector EEPROM with look-up-table containing transducer calibration (second look-up-table for cold junction sensor calibration).
- Cold junction heat facility (to assess correct connection of the thermocouple).
- Can compensate for reversed thermocouples
- Compatible with high impedance thermocouples.

RTD

- $\pm 0.1^{\circ}\text{C}$ accuracy typical, $\pm 0.25^{\circ}\text{C}$ accuracy max (RTD)
- Remote connector EEPROM with look-up-table containing transducer calibration.

Dual Voltage Input

- Two 0-5V DC inputs accurate to 0.05%FS
- Remote connector EEPROM with optional look-up-table for each input.

The Pressure Systems® 9146-R is an advanced temperature and voltage scanner. The smart connectors detailed here enable the user to terminate their thermocouples, PRT's or voltage signals with a smart connector that contains all the identification and calibration information for the smart connector. These connectors are then plugged into the 9146-R and it will automatically use the data contained within them. This turns the 9146-R into a 'plug-and-play' device and the transducer into a 'TEDS' type device.

Three distinct types of smart connector are available; for thermocouples, PRT's and voltage inputs. All plugs have internal EEPROMs (64K) so that the transducer calibration can be loaded into it. This takes the form of look-up-table(s) which can vary in size from 2 to 448 pairs.

For thermocouple measurements, the cold junction is made within the Lemo® connector (by an alloy to copper crimp) and the temperature of this junction is measured with a high accuracy thermistor.

The calibration of this thermistor can either be handled within the unit or by a second look-up-table within the Lemo® plug.

Also for thermocouples, there is the facility to heat the cold junction within the plug (via a resistor) which will enable the user to ensure that the thermocouple polarity is correct (as this can be difficult to do with mineral insulated thermocouples). The 9146-R then has the ability to compensate for reversed thermocouples.

On power up, the 9146-R will download all the calibrations within the plugs together with the sensor type. The 9146-R will then output engineering units via Ethernet for any mix of measurement types.

The smart connectors have been comprehensively tested for vibration, altitude and temperature to deal with harsh environments.

All connector types can be programmed with useful features such as calibration date, transducer information and serial number in 256 bytes of user defined memory.



Thermocouple Inputs

The Smart thermocouple connector is shown below. It features two copper tubes into which the thermocouple alloys are fitted. This is then crimped to form the cold junction. A thermistor is then closely bonded to the copper tubes to ensure an accurate measurement of the cold junction temperature.

The thermocouple connector is designed to take stainless steel sheathed fine wire thermocouples directly into the connector without the need for intermediate sheathing (although other types and size of thermocouple can be accommodated).

The EEPROM on the thermocouple connector can contain two look-up-tables, one for the thermocouple and one optional one for the thermistor. If the second look-up-table is not present, the 9146-R will use its own thermistor laws to derive the cold junction temperature.

The thermocouple connector also features a heating resistor which is closely bonded to the copper tubes. This can be activated on a per-channel basis and the corresponding heating of the cold junction monitored. The polarity of the thermocouple can then be measured.

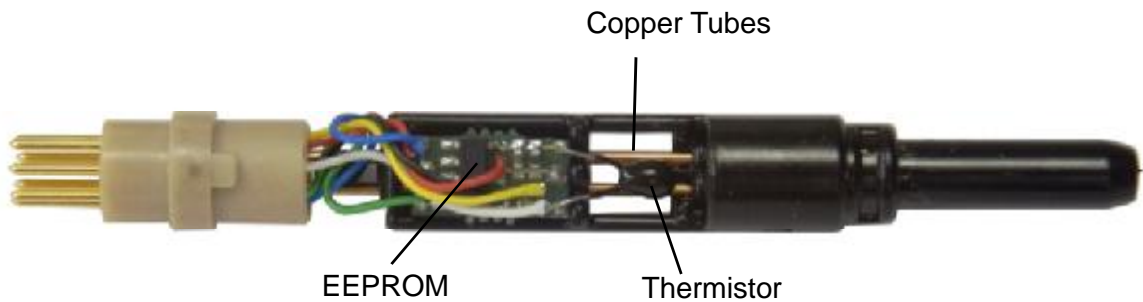

PRT / Dual Voltage Inputs

The PRT and Dual voltage inputs use the same PCB and look identical. For PRT's only one connection is made to the PCB which is the ground. All others are made direct to the Lemo pins. For Dual voltage inputs, all the connections are made to flying leads from the PCB.

The dual voltage input facilitates two analogue voltages per channel (0-5v) therefore giving it the ability to acquire 32 voltage signals per scanner.

This connector also features an internal EEPROM and there is the option to use a look-up-table for each input.

The kit supplied contains all the parts necessary to make the connections and heat shrink the cable (to ensure sufficient strain relief).

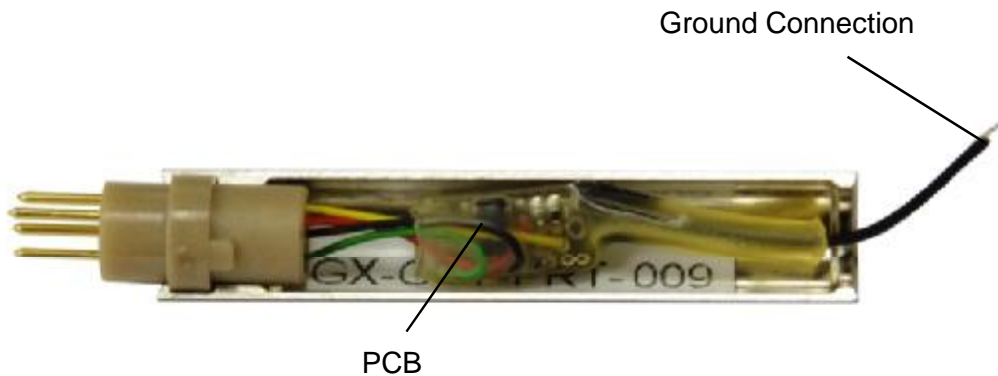

Wiring

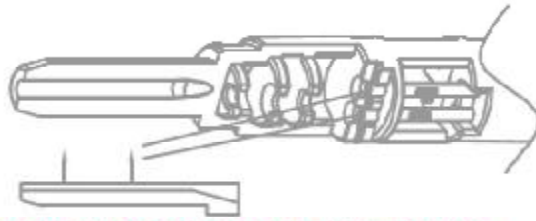

1 Apply thermal compound to thermocouple conductors and insert into copper tubes. Polarity of conductors is not important. Secure thermocouple cable into position using Loctite 4105. Fix back clamp to fully secure thermocouple cable using Loctite 4105. Shrink sleeving in place.



2

Move Thermistor clear of copper tubes. Crimp conductors into copper tubes with crimp tool

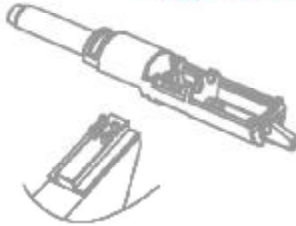

3

Re-position Thermistor to contact copper tubes at point of crimp and secure with Loctite 4105. Re-assemble into Lemo body



Wiring

Crimp using ferrule and sleeve with small heatshrink

KEY DENOTES PIN 1

Push male contacts into insulator following connection table

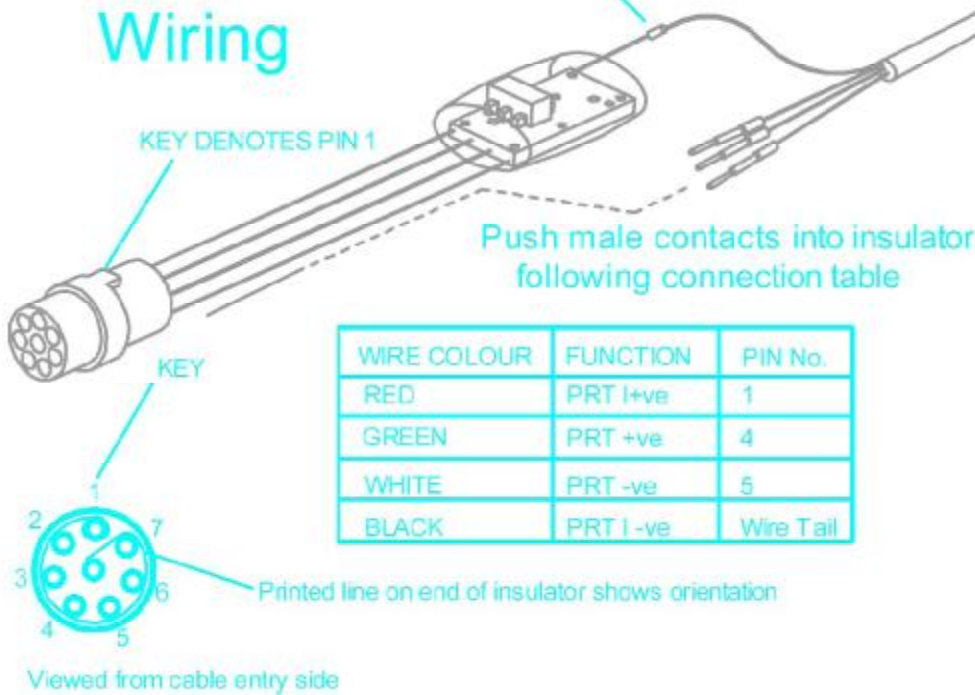

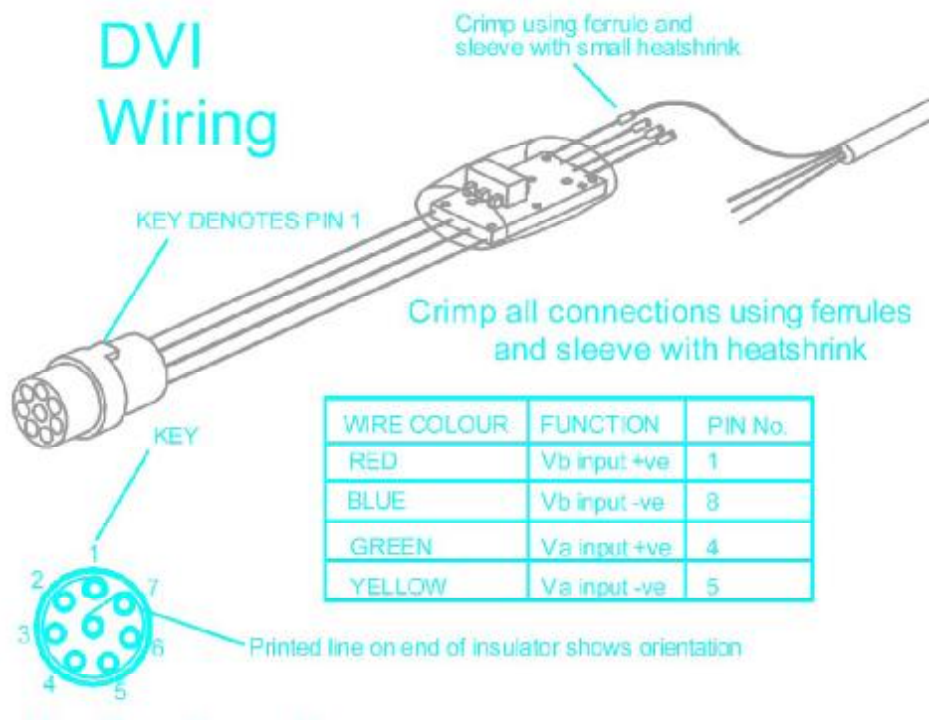

Smart Connector Part Number

SML-A-BB-CC

A = Smart connector type

T = Thermocouple

P = RTD

V = Dual voltage input

BB= Cable entry diameter

01 = 3 to 6mm diameter

02 = 4.5 to 7.5mm diameter

CC= Conductor size

01 = up to 0.2mm² (24 AWG) for thermocouples (other sizes are available, please enquire)

02 = Up to 0.5mm² (20 AWG) for PRT and voltage inputs

03 = Up to 1mm² (17 AWG) for PRT and voltage inputs

Notes

All connectors are supplied assembled, tested, serialised and programmed. The connectors are supplied in a kit with any necessary sleeving and ferrules to complete the connection.
 All connectors are supplied with a high temperature silicon strain relief. These are colour coded where Thermocouples are yellow, PRT's blue and voltage inputs green.
 Please enquire about any alternative cable sizes or programming requirements.

Smart Connector Memory Map			
PSI defined memory			
Address (hex)	Bytes	Data type	Use
0x0000	256		Reserved
0x0100	256		Look up table for input 1 (Va)
0x0100	256		Look up table for input 1 (Va)
	34		Reserved
	1	character	Channel type (numeric 1 - 255)
	2	short	Number of calibration points for look up table from 2 to 448.
	8	float	Offset and span that can be applied to look up table, set to 0 and 1 by default.
	1		Channel polarity, 0 = normal, 1 = reversed.
	209		Reserved
	1	character	Check sum
0x0200	3584	IEEE float	Look up table 1 data (32 bit IEEE floating point data pairs)
0x1000	256		Look up table for input 2 (Vb)
0x1000	256		Look up table for input 2 (Vb)
	34		Reserved
	1	character	Channel type (numeric 1 - 255)
	2	short	Number of calibration points for look up table from 2 to 448.
	8	float	Offset and span that can be applied to look up table, set to 0 and 1 by default.
	1		Channel polarity, 0 = normal, 1 = reversed.
	209		Reserved
	1	character	Check sum
0x1100	3584	IEEE float	Look up table 2 data (32 bit IEEE floating point data pairs)
User defined memory			
0x11F00	256		Suggested User Defined Memory
	8	ascii text	User part number
	8	ascii text	Chell part number
	8	ascii text	Serial number
	16	ascii text	Measurement ID for sensor 1
	16	ascii text	Sensor ID for sensor 1
	16	ascii text	Cal due date for sensor 1
	16	ascii text	Measurement ID for sensor 2
	16	ascii text	Sensor ID for sensor 2
	16	ascii text	Cal due date for sensor 2
	136	ascii text	Remaining memory capacity
Note : This is a suggested layout only. The user defined part of the memory (256 bytes) can be written and accessed in any format.			



0687

Chell Instruments Ltd
 Folgate House
 Folgate Road
 North Walsham
 Norfolk NR28 0AJ
 England

Tel.: +44 (0)1692 500555
 Fax: +44 (0)1692 500088

E-mail : sales@chell.co.uk

Web site : www.chell.co.uk