



TELEDYNE HASTINGS INSTRUMENTS

HFM-I-401

Available flow ranges: 0-10 slm to 0-350 slm (N₂)

HFM-I-405

Available flow ranges: 0-100 slm to 0-2500 slm (N₂)

FEATURES

- High accuracy in Nitrogen
 - Standard: $\pm 1\%$ full scale
 - Polynomial: $\pm(0.5\% \text{ reading} + 0.2\% \text{ full scale})$
- Mountable remote electronics package for maximum flexibility
- Hazardous Location approval pending
- Choice of RS232, RS485 or Ethernet
- Operation with analog and/or digital commands and outputs
- 4 pin D-coded M12 Digital Connector
- Built-in Totalizer measures total amount of gas added to a system
- IP65 environmental protection (NEMA 4)
- Powered with 24 VDC or ± 15 VDC
- NIST Traceable Calibration Certificate

APPLICATIONS

- Process gases
- Industrial gas distribution
- Petrochemical
- Fuel cell testing
- Pharmaceutical production
- Secondary calibration reference
- Gas generation

BENEFITS

- Multiple gas configuration (six standard gases)
- New laminar flow element design results in improved accuracy when switching gases
- High accuracy translates to higher turn down ratios and improved rangeability
- Self-Diagnostics (through Status Word) for sensor and overflow alarms allow immediate correction of unwanted overflows

400-I Series, Industrial Flowmeter



DESCRIPTION

The 400 Series is a new family of flow instruments which is specifically designed to meet the needs of the industrial gas flow market. Each instrument in the series can be driven by a +24 VDC power supply. In addition, the "I" family in the 400 Series features an IP-65 enclosure which will allow the use of the instrument in a wide variety of environments.

The electrical connection can be made via either a terminal strip located inside the enclosure or through an IP-65 compatible electrical connector, which can be quickly connected. All of the instruments include both analog and digital I/O. This signal is linear to the full scale flow rate of the measured gas.

Intensive research has resulted in a vastly improved linearity. This becomes more apparent when different gases are measured. The 400-I series minimizes the large changes in linearity that typically occur when the flowing medium changes.

For a full explanation, please see the 400-I Series white paper on www.teledyne-hi.com

When viewing the electronic version of this Product Bulletin, use this link:

<http://www.teledyne-hi.com/tech-papers/Flow-Reading.pdf>

Specifications and Standards

<i>Performance</i>	<i>HFM-I-401</i>	<i>HFM-I-405</i>
Full Scale Flow Ranges (in N ₂)	0-10 slm up to 0-350 slm	0-100 slm up to 0-2500 slm
Accuracy ¹	Standard: ± 1% full scale Optional: ± (0.5% reading + 0.2%FS)	Standard: ± 1% full scale Optional: ± (0.5% reading + 0.2%FS)
Repeatability	± 0.1% of F.S.	± 0.1% of F.S.
Operating Temperature	-20 to 70°C	-20 to 70°C
Warm up time	30 min for optimum accuracy 2 min for ± 2% of full scale	30 min for optimum accuracy 2 min for ± 2% of full scale
Settling Time/Response Time	< 2.5 seconds (to within ± 2% of full scale)	< 2.5 seconds (to within ± 2% of full scale)
Temperature Coefficient of Zero	< ±0.05% of Full Scale /°C	< ±0.05% of Full Scale /°C
Temperature Coefficient of Span	< ±0.16% of reading/°C	< ±0.16% of reading/°C
Operating Pressure -Maximum	Standard: 500 psig Optional: 1500 psig	Standard: 500 psig Optional: 1000 psig
Pressure Coefficient of Span	< 0.01%of reading /psi (N ₂ , 0-1000 psig)	< 0.01%of reading /psi (N ₂ , 0-1000 psig)
Pressure Drop(N ₂ @14.7 psia)	< 1.0 psi at full scale flow	< 5.0 psi at full scale flow
Attitude Sensitivity of Zero	< 2% of F.S.	< 2% of F.S.
<i>Electrical</i>		
Power Requirements	18-38 VDC, 3.5 watts(Ethernet) 2.5 watts(RS232/485)	18-38 VDC, 3.5 watts(Ethernet) 2.5 watts(RS232/485)
Analog Output	Standard: 4 – 20 mA Optional: 0-10 VDC, 0-20 mA, 0-5 VDC, 1-5 VDC	Standard: 4 – 20 mA Optional: 0-10 VDC, 0-20 mA, 0-5 VDC, 1-5 VDC
Digital Output	Standard: RS 232 Optional: RS 485 Optional: Ethernet	Standard: RS 232 Optional: RS 485 Optional: Ethernet
Analog Connector	Standard: Terminal Block – M16 Cable Gland Optional: 12 pin Circular Connector	Standard: Terminal Block – M16 Cable Gland Optional: 12 pin Circular Connector
Digital Connector	4 pin, D-coded M12	4 pin, D-coded M12
<i>Mechanical</i>		
Fittings	Standard: 1/2" Swagelok Optional: ½" VCO®, ½" VCR®, ¾" Swagelok, 10mm Swagelok, 3/8" male NPT, ½ male NPT 12mm Swagelok, ¾"-16 SAE/MS straight thread	Standard: 1" Swagelok Optional: 1" VCO®, 1" VCR®, ¾ Swagelok 1" male NPT, ¾ male NPT, 1 5/16th"-16 SAE/MS straight thread
Leak Integrity	< 1x10 ⁻⁸ sccs He	< 1x10 ⁻⁸ sccs He
Wetted Materials	316L SS, Nickel 200, 302 SS, Viton®	316L SS, Nickel 200, 302 SS, Viton®
Weight (approx.)	12 lb (5.5 kg)	18 lb (8 kg)

¹ Calibration gas only (Air or N₂ @ 19.7 psia)

Standards

EN61010-1:2001 Safety of Electrical Equipment for Measurement, Control and Laboratory Use
 EN 61326:1997, A2:2000 Electrical equipment for measurement, control and laboratory use - EMC requirements
 EN 55011:1998, A2:1999 Conducted and Radiated Emissions
 EN 61000-4-2:1998, A2:1998, A2:2000 Electrostatic Discharge
 EN 61000-4-3:2002 Radiated RF Immunity
 EN 61000-4-4:2004 Electrical Fast Transient/Burst
 EN 61000-4-5:1995, A1:2000 Surge
 EN 61000-4-6:2003, A2:2004 Conducted RF
 EN 61000-4-8:1993, A2:2000 Magnetic Field
 EN 61000-4-11:2004 Voltage Dips
 Hazardous Location Certification—Class 1, Division 2(Pending Certification)
 Enclosure: IP 65/NEMA 4 (Pending Certification)

Hastings Instruments reserves the right to change or modify the design of its equipment without any obligation to provide notification of change or intent to change.

Viton® is a registered trademark of Dupont Performance Elastomers

HFM-I-401 Outline Drawing

FITTINGS		
FITTING TYPE		DIM "A"
10mm SWAG. 3/4"-16		7.71" [195.83]
12mm SWAG. 3/4"-16		7.71" [195.83]
1/2" SWAG. 3/4"-16		7.71" [195.83]
3/4" SWAG. 3/4"-16		8.01" [203.45]
1/2" VCO 3/4"-16		8.13" [206.50]
3/8" NPT 3/4"-16		7.91" [200.91]
1/2" NPT 3/4"-16		8.27" [210.06]
1/2" VCR 3/4"-16		8.57" [217.68]

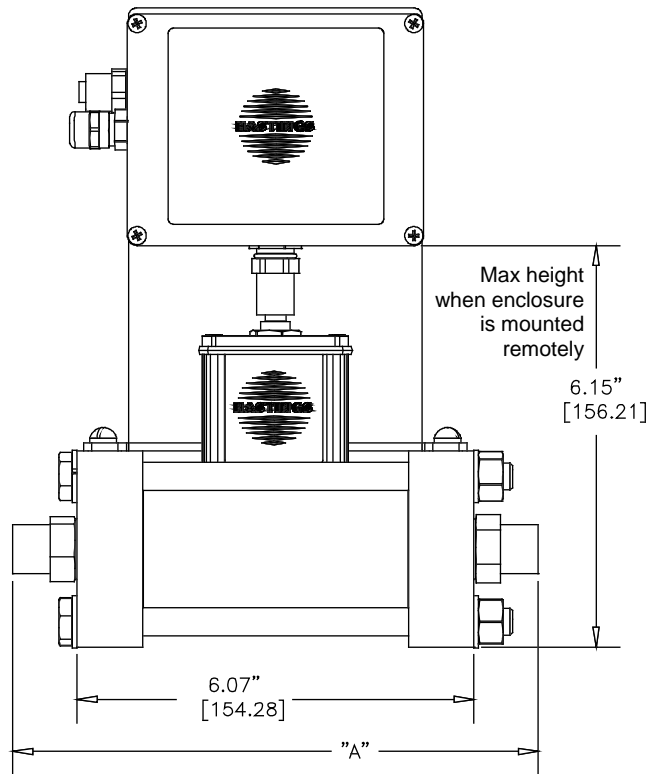
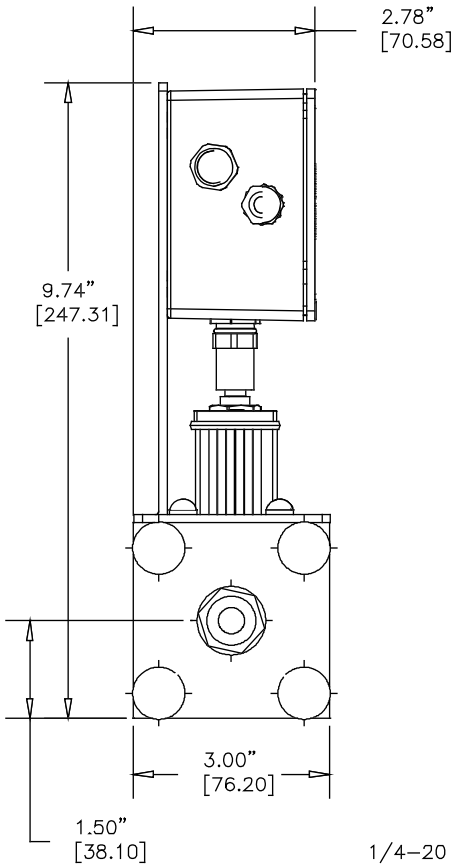
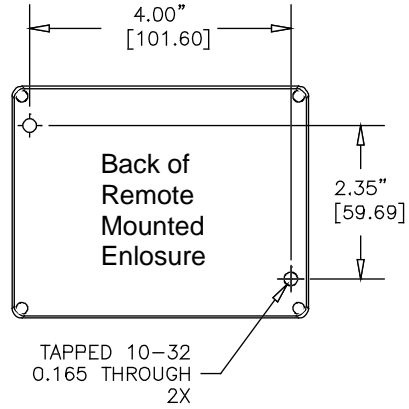

1/4-20 X .375

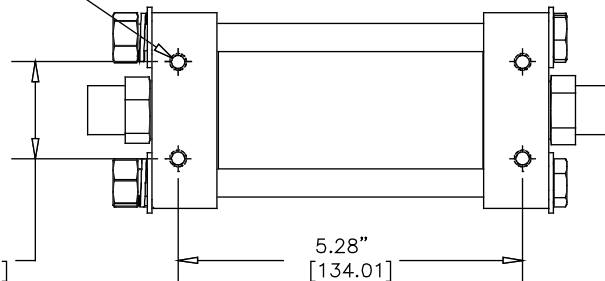

TOLERANCE ON DIM. IS ±.05"

HFM-I-405 Outline Drawing

FITTINGS	
FITTING TYPE	DIM "A"
3/4" SWAGELOK	8.01" [203.45]
1" SWAGELOK	8.21" [208.53]
3/4" MALE NPT	8.47" [215.13]
1" MALE NPT	8.85" [224.79]
1" VCO	8.47" [215.14]
1" VCR	9.49" [241.05]

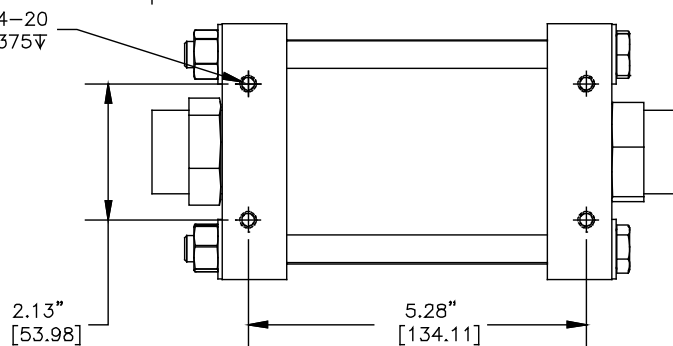
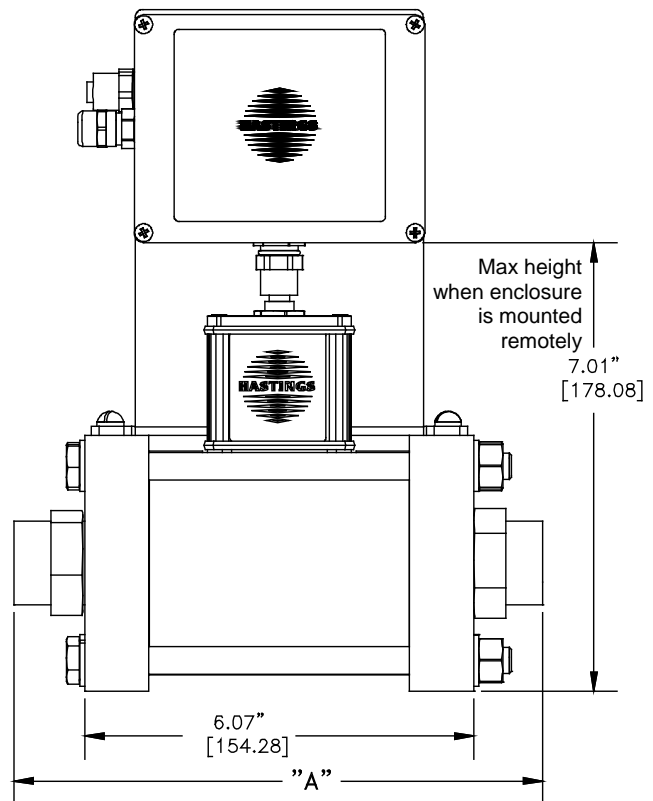
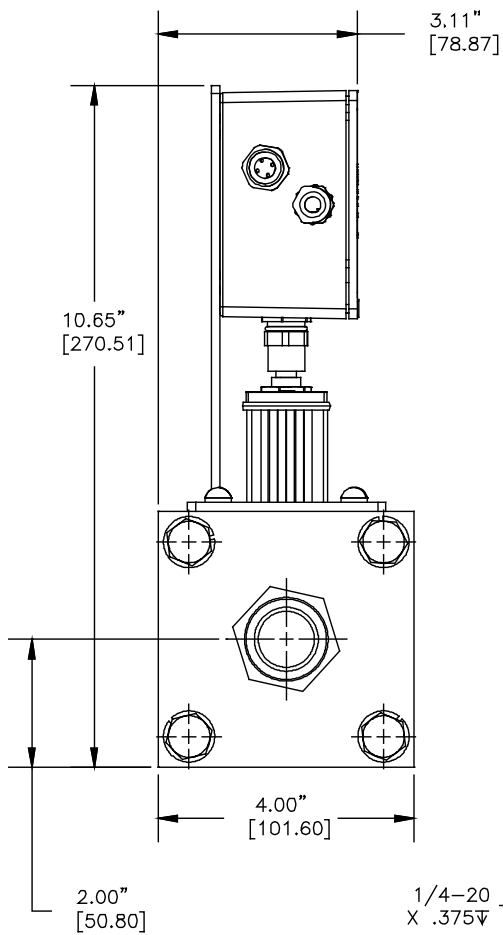
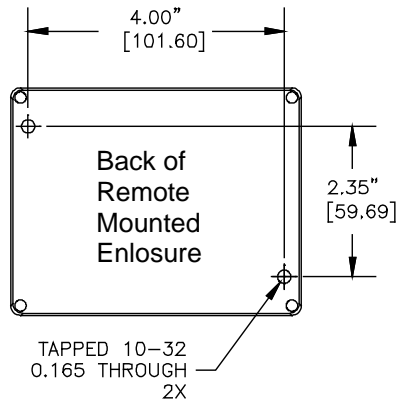

TOLERANCE ON DIM. IS ± 0.05 "

Mass Flow Range and Gas Selection

A mass flow meter measures mass. That mass is converted to familiar volumetric units using a known density factor. Since the density of gases changes with changing temperature and pressure, one value must be specified. This specification is the **standard temperature and pressure** or STP. When this calculation is done, the units are called **standard** liters per minute (SLM) or **standard** cubic feet per minute (SCFM), etc

When ordering or requesting a quotation, please provide the following information

Note: If multiple gas calibration certificates are ordered, this information must be provided for each gas

STP— _____ Example— 0 ° C and 760 Torr
 21.1° C and 760 Torr
 70 ° F and 760 Torr

Flow Units— _____ Example— SLM (Standard Liters per Minute)
 SCFM (Standard Cubic Feet per Minute)
 SCCM (Standard Cubic Centimeters per Minute)
 Lbs per Hour

Full Scale Range
 _____ Example— 0—100 SLM

Note: This is the maximum flow rate the instrument will flow.

Gas— _____ Example— Air
 Hydrogen

Note: All instruments are calibrated with Nitrogen or Air and a gas conversion factor is used to convert the flow rate to the desired gas. Accuracy may vary when gases other than nitrogen or air are used.

Accessories

This unit comes standard with:

- NIST Traceable Calibration Certificate
- Analog and Digital Output.
- Choice of Remote Electronics or Mounting Bracket
- Six Standard Gases as shown in Table 1. Custom Gases quoted separately

Table 1-Gas Record Table

Record#	Gas
0	Nitrogen
1	Air
2	Helium
3	Hydrogen
4	Argon
5	Oxygen
6	Custom
7	Custom

Description	Model Number	Comments	
Remote Electronics Cables			
2 meter cable remote mounting cable	CB-8P-M12-2MRA		
5 meter remote mounting cable	CB-8P-M12-5MRA		
10 meter remote mounting cable	CB-8P-M12-10MRA		
401 local bracket - mount direct to sensor	14-03-002		
405 local bracket - mount direct to sensor	14-03-001		
Digital Communications			
9 pin RS232 to 400 series M12 connector	CB-RS232-M12	USB to 9 pin RS232 connector	CB-USB-RS232
Digital M12 connector to M12 connector	CB-ETHERNET-M12	RJ45 ethernet to M12 ethernet connector	CB-RJ45-M12

* Contact factory for sourcing 24 Volt power supply

400-I Series, Selection Chart

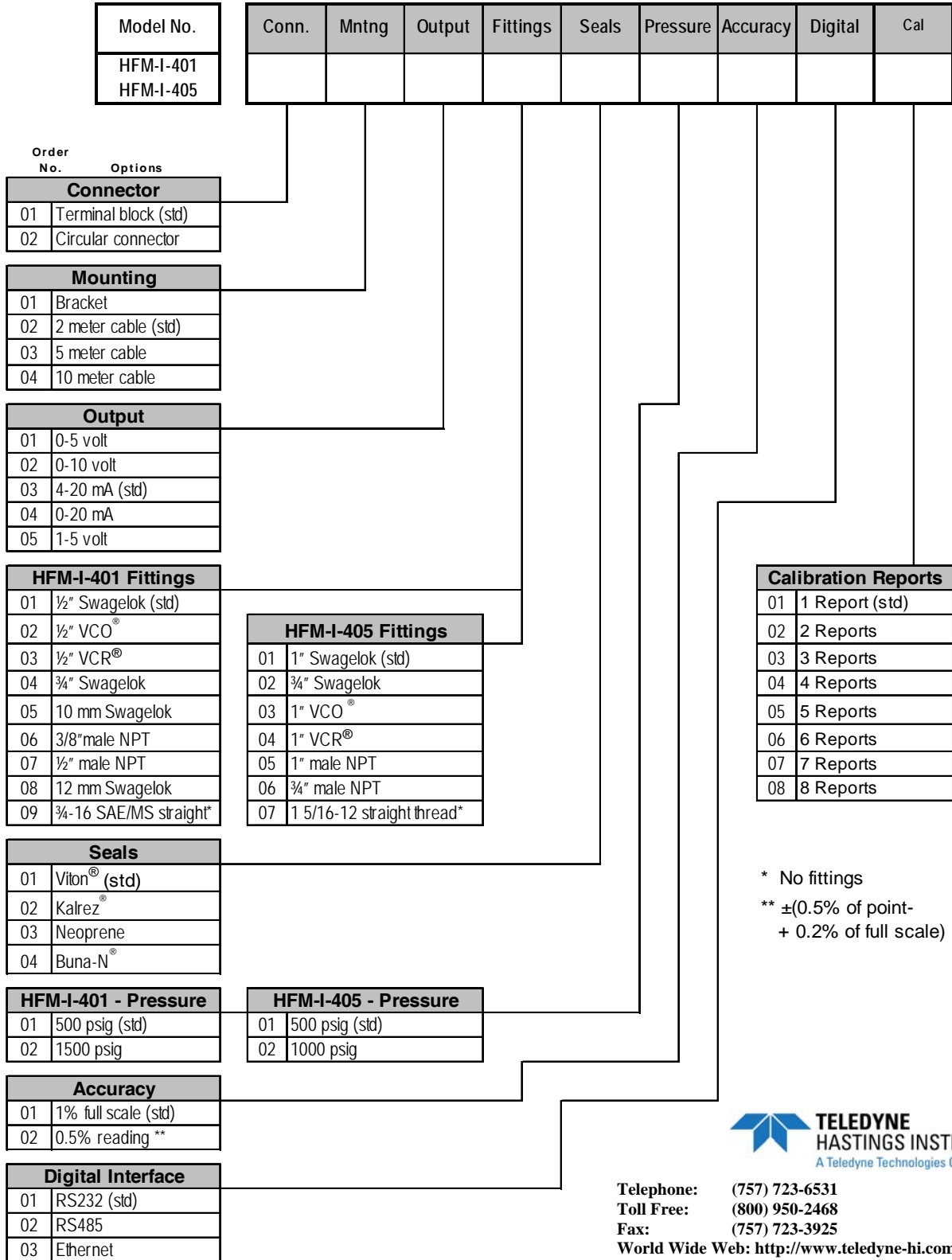

Telephone: (757) 723-6531
Toll Free: (800) 950-2468
Fax: (757) 723-3925
World Wide Web: <http://www.teledyne-hi.com>
E-mail: hastings_instruments@teledyne.com
P.O. Box 1436
Hampton, VA 23661

