

PSI Temperature Scanners



- Networkable Voltage & Temperature Instruments
- Withstand 30 g and 160 dB
- Smart Connector with Auto Sensor Discovery
- NetScanner™ Compatible

DESCRIPTION

The PSI 9146 and 9046-S are networkable instruments to measure thermocouples, RTDs or voltages. On-board signal conditioning, analog to digital conversion and microprocessor compensation combine to provide high accuracy data. Host PC interface is achieved via Ethernet at data throughput rates up to 33 Hz in Engineering Units or 100 Hz in raw count data format. The 9146 and 9046-S are part of the NetScanner™ family of instruments. All NetScanner instruments share a common power, communication and software protocols.

Each of the three temperature scanners has unique termination features. The 9146-R uses LEMO® Circular connectors for 3 or 4 wire RTDs and an innovative new technology called Smart Connectors™ to provide automatic sensor identification and compensation by combining independent uniform temperature reference junctions with EEPROM memory. This technology allows the 9146-R to measure RTDs, fine gauge thermocouples or voltages. The 9146-T uses a screw terminal interface to provide convenient connection to 2 or 3 wire medium gauge thermocouples. The 9046-S uses crimp pins for direct sensor connection and a gland seal to provide an environmentally sealed instrument capable of measuring any combination of thermocouples and RTDs.

The NetScanner family of instruments provides a complete networkable measurement solution for temperature, pressure, barometric and voltage measurements. Capable of withstanding high shock, vibration and acoustic noise, these IP rated instruments are ideally suited for turbine engine testing and similar demanding environments.

FEATURES

- Rugged Splashproof Enclosure
- Temperature and Voltage Measurements
- Individual UTR per channel

APPLICATIONS

- Turbine Engine Test Cells
- Compressor Test Cells
- Process Monitoring

PSI Temperature Scanners

SPECIFICATIONS

Parameter	9146-R	9146-T	9046-S	Comment
Input Types	Thermocouple RTD Volts/mV	Thermocouple	Thermocouple RTD Volts/mV Resistance	
Number of Inputs	16 or 32	16	16	
Input Connectors	Smart Connector™ LEMO Connector	Screw Terminal #8 Binder Head MS 3470L14-15P	Crimp Pins	
Scan Rates	33 Hz/Channel-EU 100 Hz/Channel-Raw		5 Hz/Channel-EU-RTD 10 Hz/Channel-EU-TC 33 Hz/Channel-Volts	
Communication	Ethernet 10/100 Base-T Auto-negotiating Full Duplex		Ethernet 10 Base-T Half Duplex	
Protocol	TCP and UDP			
Compensated Temp Range	-30 to 60 °C			
Operating Temp Range	-30 to 70 °C			
IP Rating	IP-66	IP-54	IP-54	
Vibration ¹	20 g	30 g	N/A	Peak Acceleration
Shock	30 g		N/A	Peak Shock
Acoustic	160dB acoustical noise referenced to 2×10^{-5} N/m ² for 30 min		N/A	
Size	9.5 x 3.5 x 3.2 inches 24.1 x 8.9 x 8.2 cm	9.5 x 3.5 x 3.4 inches 24.1 x 8.9 x 8.6 cm	9.5 x 3.5 x 3.8 inches 24.1 x 8.9 x 9.6 cm	
Weight	4.5 lb. 2.0 kg.	5.3 lb. 2.4 kg	6.5 lb. 3.0 kg	
Input Voltage	18 – 36 VDC			unregulated
Input Current	200 mA			max @ 24 VDC
Trigger	5 VDC			0 to 5V TTL
Common Mode Voltage	10 VDC	10 VDC	5 VDC	

1 Requires vibration shock mount kit P/N 9SM.

PSI Temperature Scanners

SPECIFICATIONS

Accuracy and Resolution

RTD – Volts - Resistance

Parameter	9146-R	9146-T	9046-S	Comment
Accuracy / Resolution				
RTD	0.25 °C / 0.023 °C	N/A	0.304 °C / 0.019 °C	
Volts	N/A	N/A	2.500 mV / 0.153 mV	Gain 1
	0.15 mV / 0.015 mV	N/A	N/A	Gain 10
	N/A	N/A	0.125 mV / 0.008 mV	Gain 20
	N/A	N/A	0.056 mV / 0.003 mV	Gain 45
	0.017 mV / 0.002 mV	N/A	0.028 mV / 0.002 mV	Gain 90
Resistance	N/A	N/A	40.000 Ω / 2.442 Ω	Gain 1
	N/A	N/A	N/A	Gain 10
	N/A	N/A	0.554 Ω / 0.034 Ω	Gain 20
	N/A	N/A	0.232 Ω / 0.014 Ω	Gain 45
	0.10 Ω / 0.009 Ω	N/A	0.114 Ω / 0.007 Ω	Gain 90

Accuracy and Resolution

Thermocouples

Thermocouples	ASTM RANGE ACCURACY / RESOLUTION ²	ASTM RECOMMENDED RANGE	FULL RANGE ACCURACY / RESOLUTION ¹	FULL RANGE
9146-R & 9146-T				
J	0.39 °C / 0.03 °C	0 to 760 °C	0.41 °C / 0.03 °C	-210 to 1200 °C
K	0.53 °C / 0.04 °C	-200 to 1260 °C	0.64 °C / 0.06 °C	-270 to 1370 °C
T	0.53 °C / 0.04 °C	-200 to 370 °C	0.72 °C / 0.07 °C	-270 to 400 °C
N	0.84 °C / 0.08 °C	-270 to 1300 °C	0.84 °C / 0.08 °C	-270 to 1300 °C
E	0.36 °C / 0.03 °C	-200 to 900 °C	0.44 °C / 0.04 °C	-270 to 1000° C
R	1.59 °C / 0.15 °C	0 to 1480 °C	1.59 °C / 0.15 °C	-50 to 1760 °C
S	1.74 °C / 0.17 °C	0 to 1480 °C	1.75 °C / 0.17 °C	-50 to 1760 °C
B	1.69 °C / 0.16 °C	870 to 1700 °C	4.92 °C / 0.31 °C	0 to 1820 °C
9046-S				
J	0.59 °C / 0.03 °C	0 to 760 °C	0.62 °C / 0.03 °C	-210 to 1200 °C
K	0.82 °C / 0.04 °C	-200 to 1260 °C	0.99 °C / 0.06 °C	-270 to 1370 °C
T	0.82 °C / 0.04 °C	-200 to 370 °C	1.11 °C / 0.07 °C	-270 to 400 °C
N	1.30 °C / 0.08 °C	-270 to 1300 °C	1.30 °C / 0.08 °C	-270 to 1300 °C
E	0.54 °C / 0.03 °C	-200 to 900 °C	0.67 °C / 0.04 °C	-270 to 1000° C
R	2.59 °C / 0.15 °C	0 to 1480 °C	2.59 °C / 0.15 °C	-50 to 1760 °C
S	2.83 °C / 0.17 °C	0 to 1480 °C	2.84 °C / 0.17 °C	-50 to 1760 °C
B	2.74 °C / 0.16 °C	870 to 1700 °C	7.48 °C / 0.31 °C	0 to 1820 °C

² Average accuracy and resolution over specified measurement range. See User's Manual for accuracies at specific temperatures.

PSI Temperature Scanners

THEORY OF OPERATION

The PSI Temperature Scanners are designed to measure temperatures and voltages within gas turbine test cells. They withstand high vibration, shock, acoustic noise and liquids associated with this demanding environment. Three versions exist, each with unique sensor connections. All three instruments output temperature data in Kelvin, Celsius, or Fahrenheit digitally compensated for zero, span, nonlinearity, and ambient temperature effects. They also check for open circuit conditions continuously while data is being acquired, signaling a fault condition within 1 second of its occurrence. Power and communication are provided through a single bayonet style locking circular connector and common cable assembly. Linearization coefficients for Types B, E, J, K, N, R S, and T are built into the firmware. Users may also enter custom coefficients associated with special calibrations or additional thermocouple types.

The 9146-R incorporates 16 LEMO Circular Sockets for reliable and convenient thermocouple and RTD sensor connection. Smart Connectors offer automatic sensor identification, hookup verification, and customized calibration coefficients on a per channel basis. Up to 32 voltage measurements are available per unit.

The 9146-T incorporates integral screw terminal connections appropriate for grounded and un-grounded thermocouples. Each of the 16 inputs has a separate uniform temperature reference (UTR) to ensure system accuracy in thermally dynamic environments.

The 9046-S uses crimp pin connections for thermocouple, RTD and voltage measurements. Sensors enter the unit through a side access 3/4" MNPT conduit fitting.



**9146-R Smart Connector
for RTD Measurements**

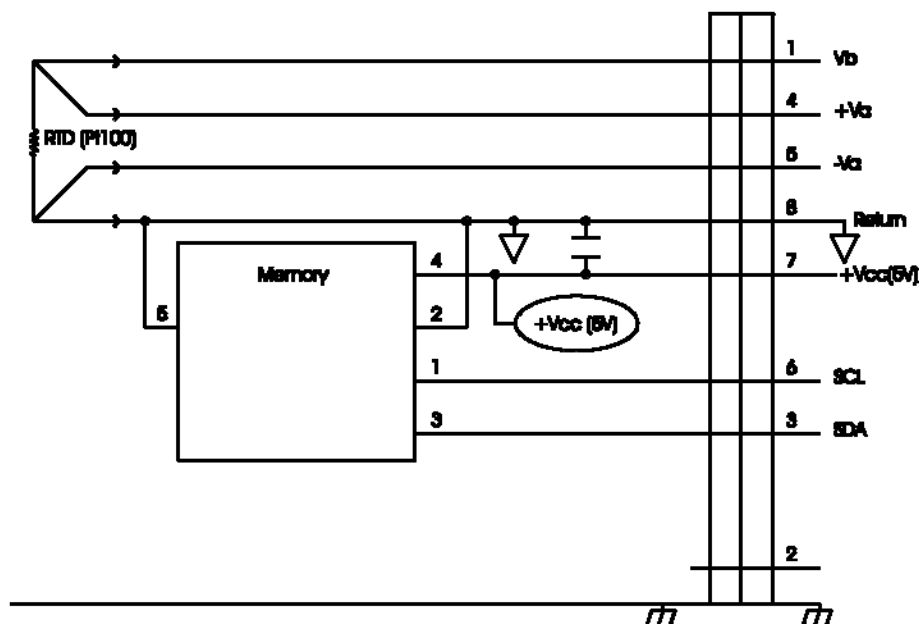

PSI Temperature Scanners

9146-R CONNECTION DIAGRAMS

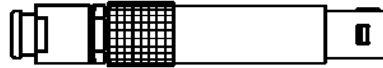

9146-R Smart Connector
for Thermocouple Measurements

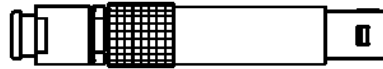
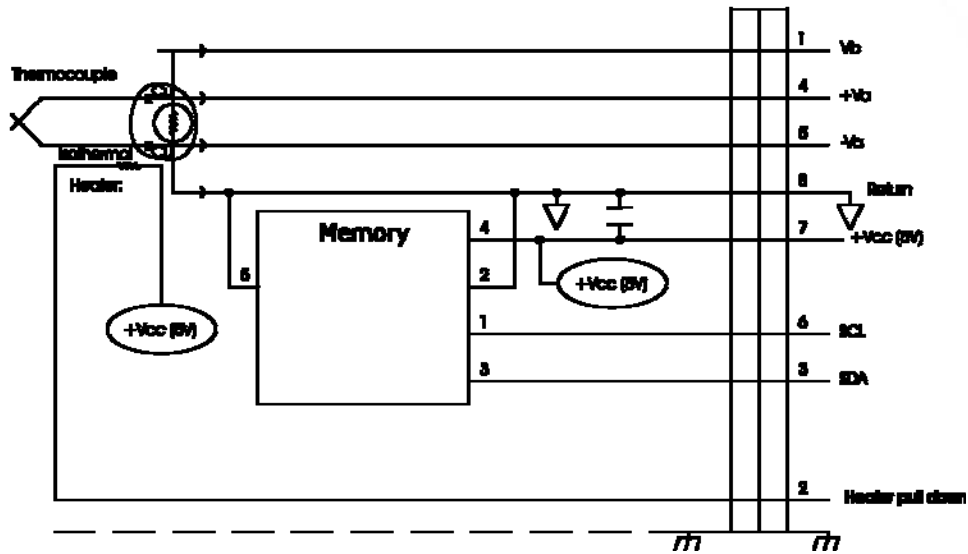

9146-R Smart Connector
for Dual Voltage Measurements

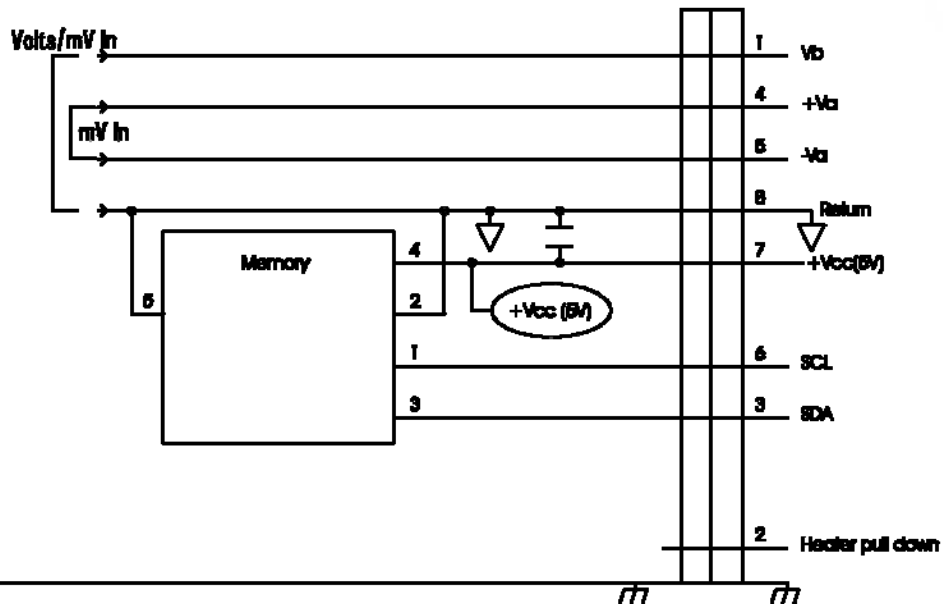

PSI Temperature Scanners

9146-R CONNECTION DIAGRAMS

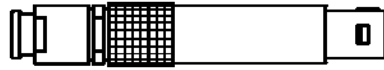

9146-R Smart Connector
for 0-5 VDC Measurements

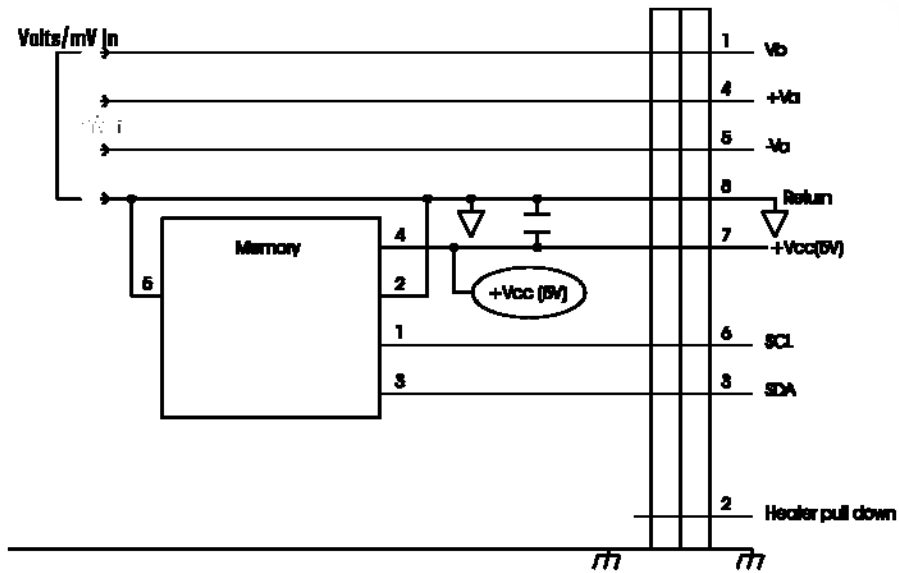

9146-R Smart Connector
for 0-55 mV Measurements

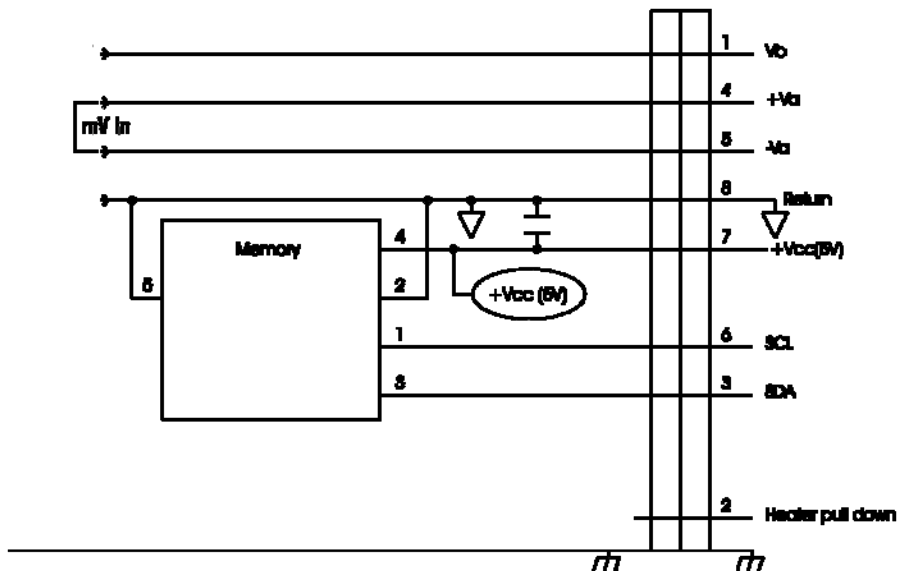

PSI Temperature Scanners

9146-T AND 9146-S CONNECTION DIAGRAMS

9146-T
for Thermocouple Connections

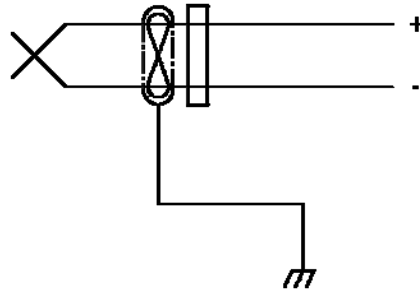

9046-S
for Thermocouple Connections

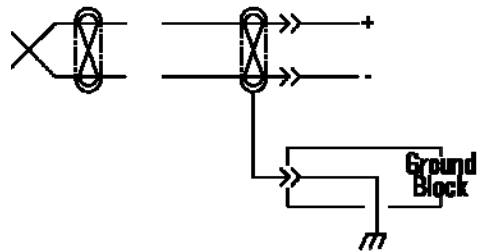

9046-S
for RTD Measurements

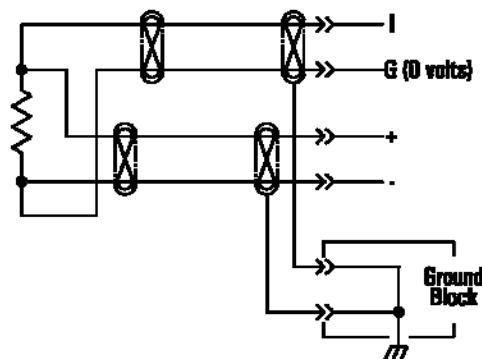

PSI Temperature Scanners

FRONT PANEL LAYOUT 9146-R & 9146-T

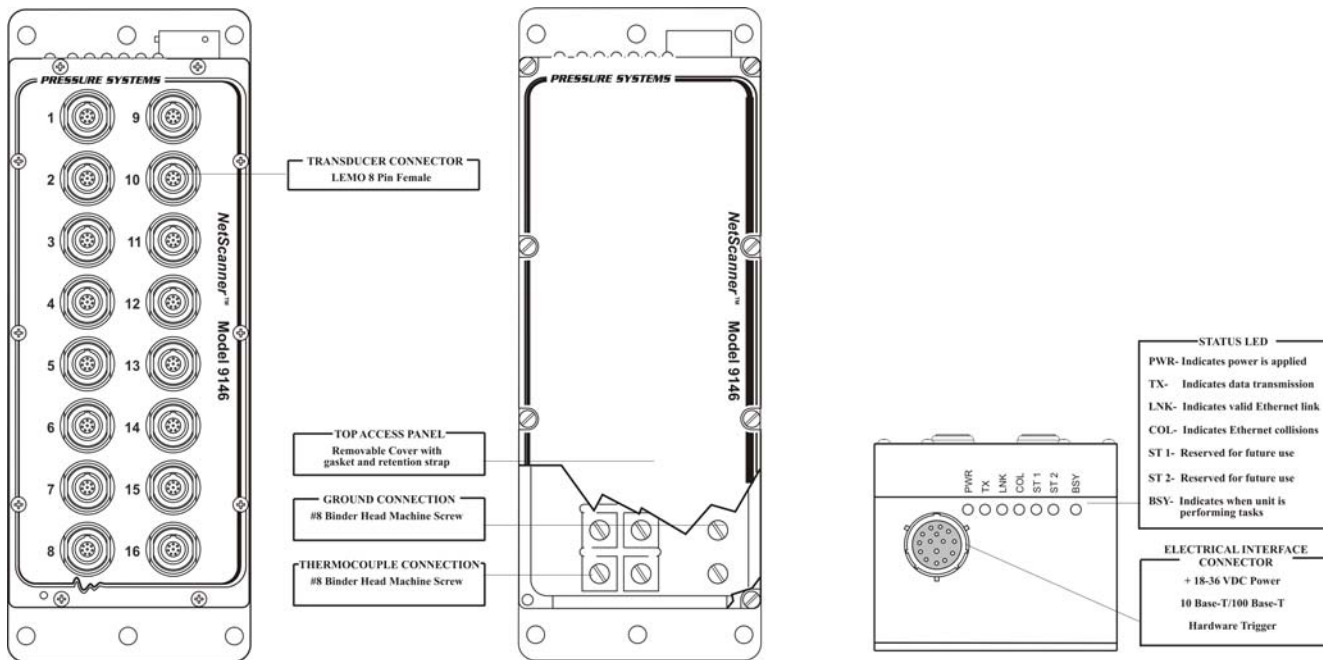

FRONT PANEL LAYOUT 9046-S

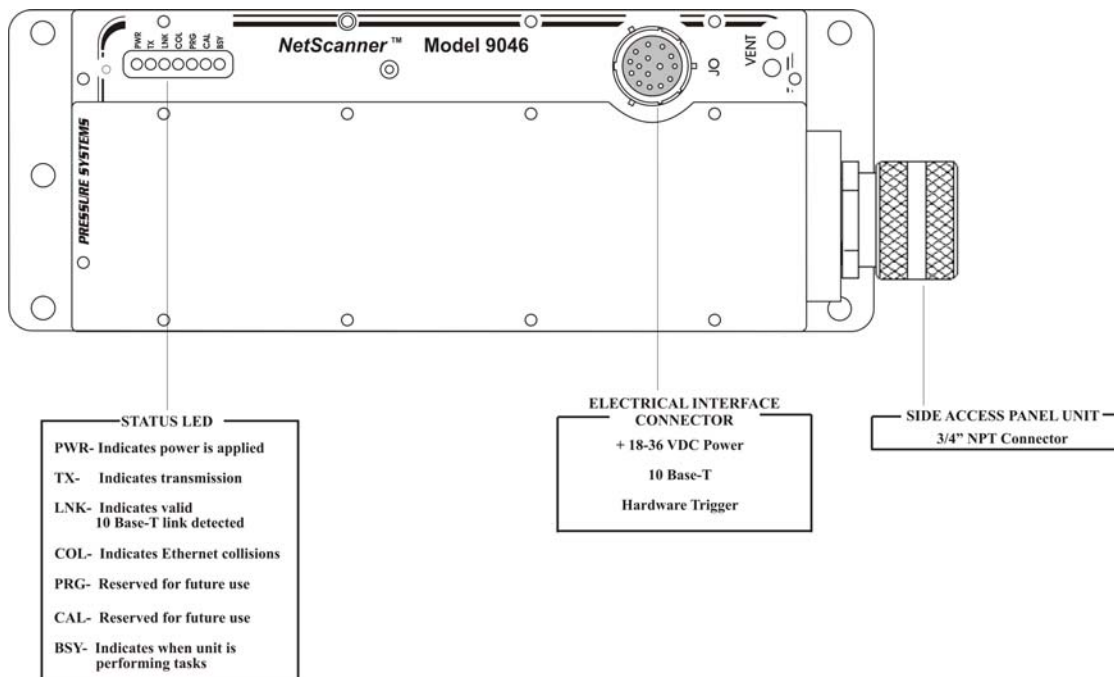

PSI Temperature Scanners

NETWORKING EXAMPLES

Single Scanner Connection

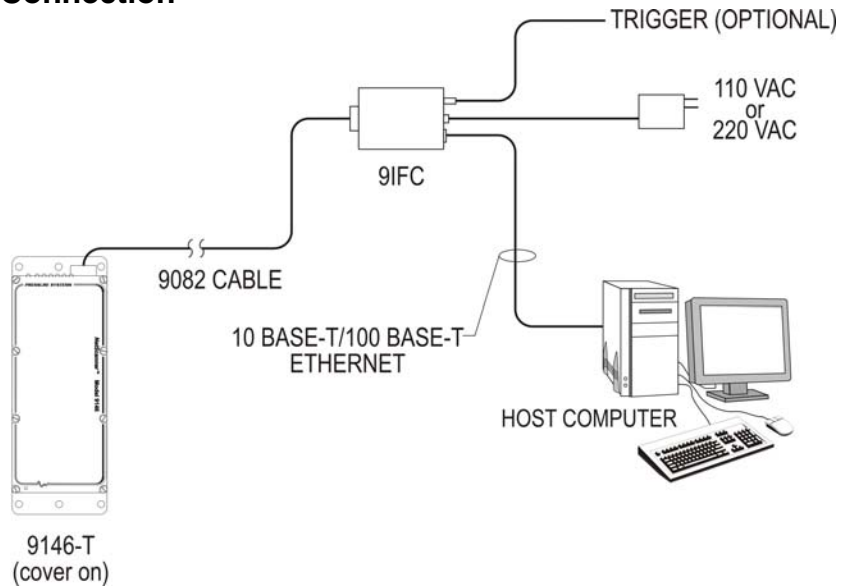

Multiple Scanner Network

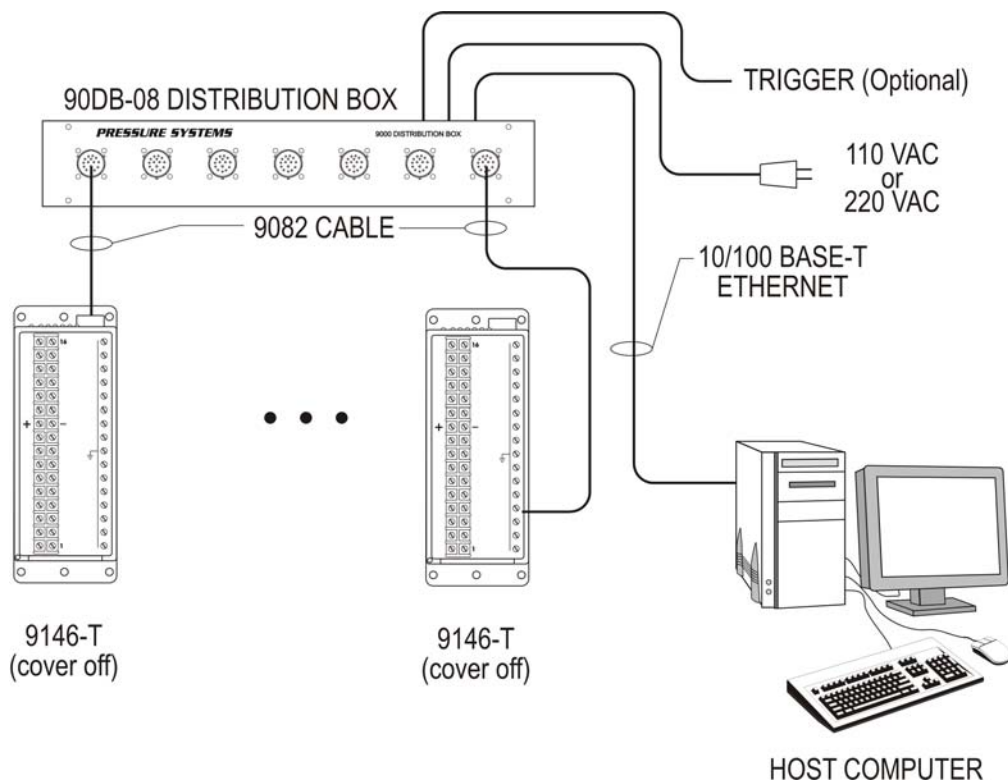

PSI Temperature Scanners

DIMENSIONS 9146-R & 9146-T

9146-R

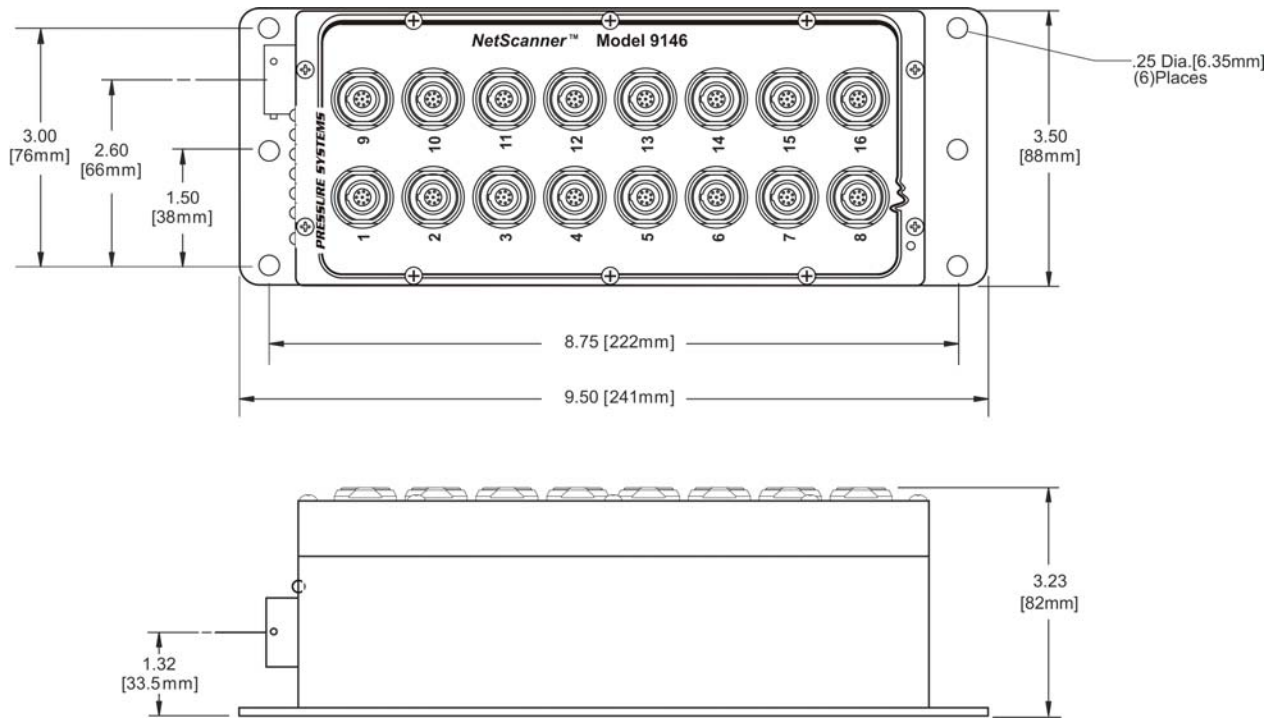

9146-T

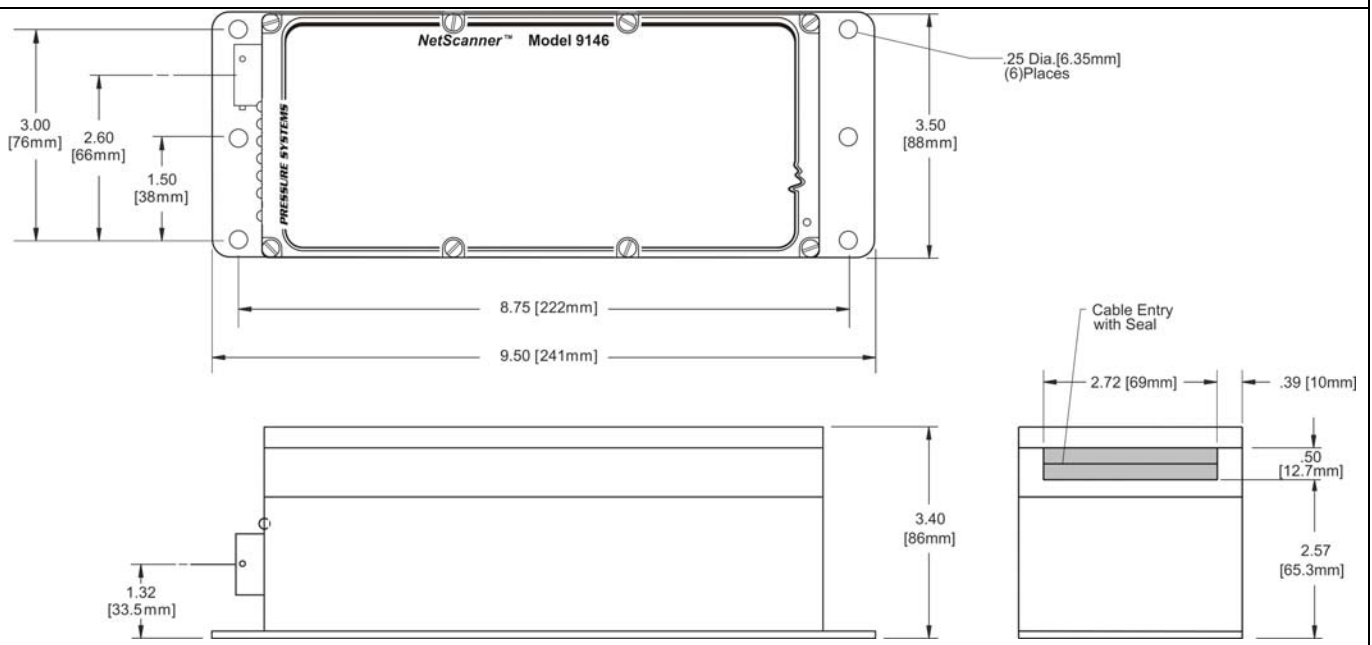

PSI Temperature Scanners

DIMENSIONS 9046-S

9046-S

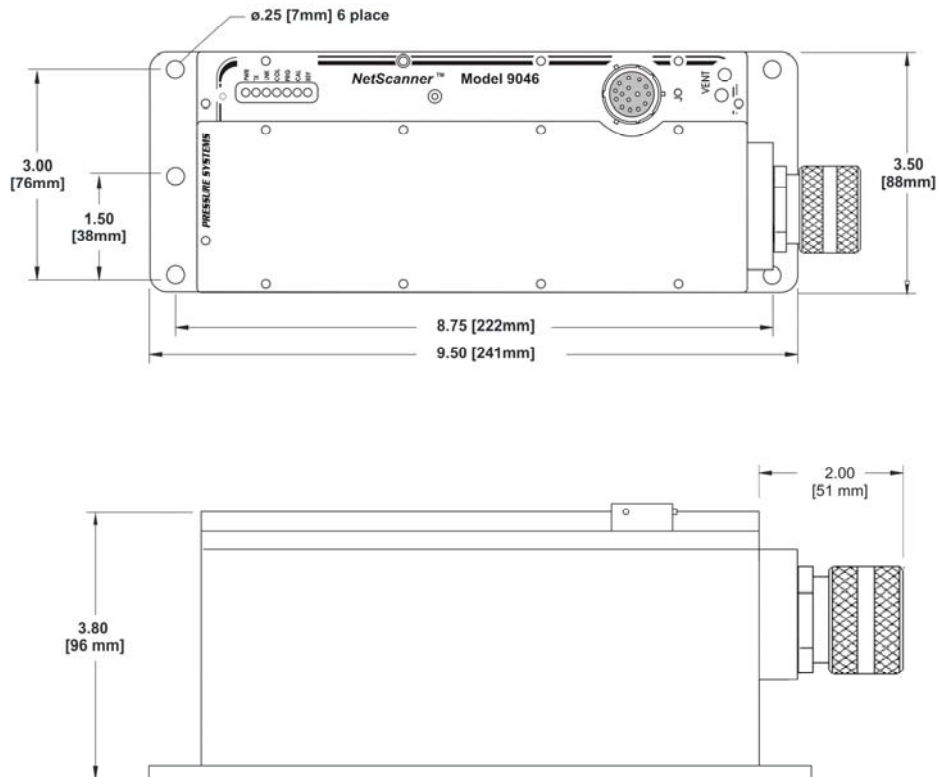

Measurement Specialties
 1000 Lucas Way
 Hampton, VA 23666
 Tel: 1-800-328-3665; 757-766-1500
 Fax: 1-757-865-8744
 Sales: pvg.cs.amer@meas-spec.com

The information in this sheet has been carefully reviewed and is believed to be accurate; however, no responsibility is assumed for inaccuracies. Furthermore, this information does not convey to the purchaser of such devices any license under the patent rights to the manufacturer. Measurement Specialties, Inc. reserves the right to make changes without further notice to any product herein. Measurement Specialties, Inc. makes no warranty, representation or guarantee regarding the suitability of its product for any particular purpose, nor does Measurement Specialties, Inc. assume any liability arising out of the application or use of any product or circuit and specifically disclaims any and all liability, including without limitation consequential or incidental damages. Typical parameters can and do vary in different applications. All operating parameters must be validated for each customer application by customer's technical experts. Measurement Specialties, Inc. does not convey any license under its patent rights nor the rights of others.